



Hydraulic crawler drill

Perforatrice idraulica

C7 NG

Dati tecnici Technical Specifications

C7 NG



Caratteristiche Carro		Undercarriage		
Larghezza sottocarro	Overall width of undercarriage	8.2 ft	2500 mm	
Larghezza pattini	Track shoes width	19,7 in	500 mm	
Lunghezza cingoli	Overall track length	12 ft	3628 mm	
Velocità di traslazione	Travel speed	1 mph	1,5 km/h	
Pendenza max. superabile	Max. gradeability	37%	20°	
Pressione al suolo	Ground pressure	10,7 PSI	7,4 N/cm ²	
Motore		Engine		
Tipo	Type	Deutz TCD 2012 L06 2V (EPA/COM III)		
Potenza a 2300 giri	Rated power at 2300 r.p.m.	200 HP	147 kW	
Mast		Mast		
Lunghezza mast	Mast length	8850 mm	12165 mm	
		29 ft	40 ft	
Corsa testa di rotazione	Stroke of rotary head	7080 mm	10400 mm	
		23 ft	34 ft	
Forza di estrazione	Extraction force	80 kN	80 kN	
		8 ton	8 ton	
Spinta sull'utensile	Crowd force	40 kN	40 kN	
		4 ton	4 ton	
Morse		Clamps		
Diametro	Diameter	M4/M4S	M5/M5S	M7/M7S
		60 ÷ 305 mm	90 ÷ 406 mm	90 ÷ 406 mm
		2.4 ÷ 12 in	3.5 ÷ 16 in	3.5 ÷ 16 in
Forza di chiusura	Clamping force	250 kN	250 kN	250 kN
		25 ton	25 ton	25 ton
Corsa di estrazione	Extraction stroke	—	—	1500 mm
				5 ft
Testa di rotazione		Rotary head		
Coppia max.	Max. torque	14,750 lbf.ft		20 kNm
Giri max.	Max. speed	199 rpm		199 rpm
Ingombri e pesi		Dimensions and weights		
Lunghezza	Length	11087 mm		13000 mm
Larghezza	Width	2500 mm		2500 mm
Altezza	Height	3100 mm		3100 mm
Peso attrezzatura	Weight of rig	22000 kg		23000 kg



C7 NG

Dimensioni Dimensions

Versione mast lungo
Long mast version

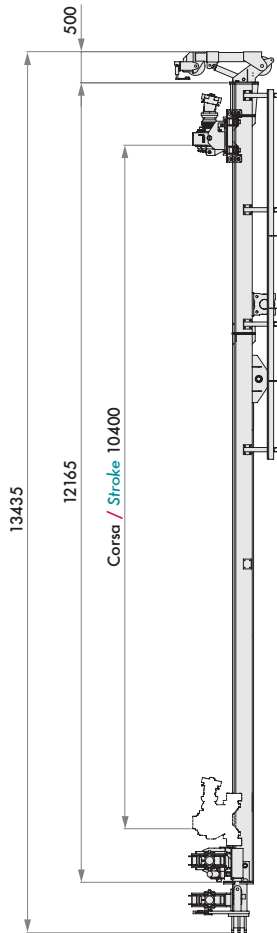

Versione doppia testa
Double head version

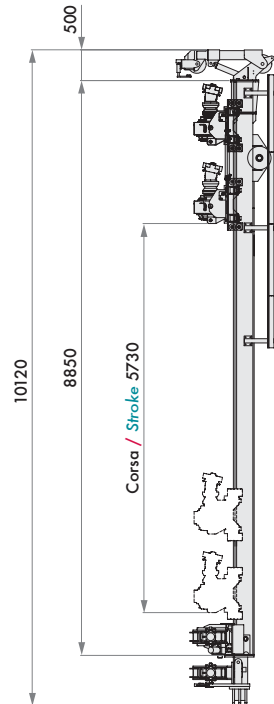

Versione mast standard
Standard mast version

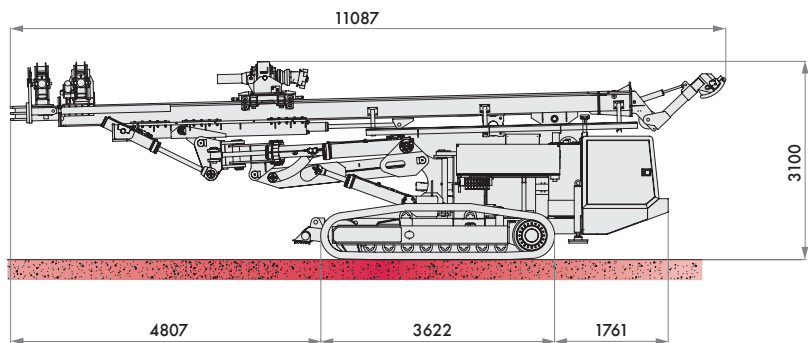
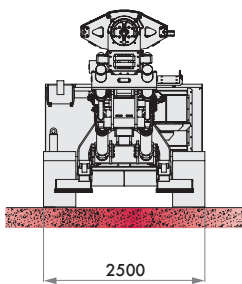
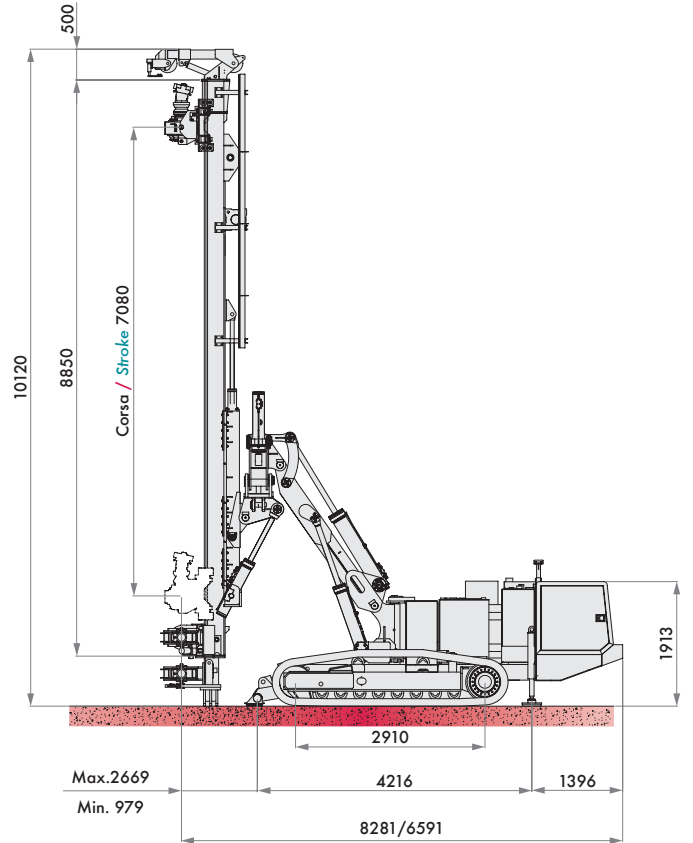

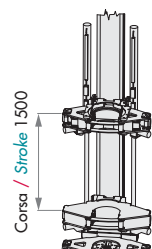
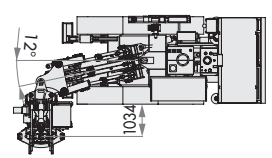
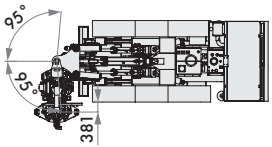
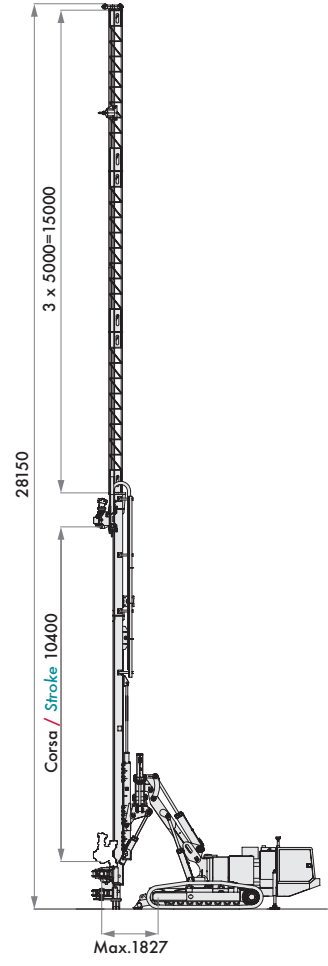
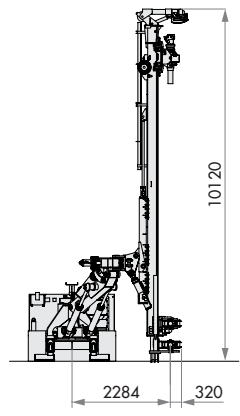
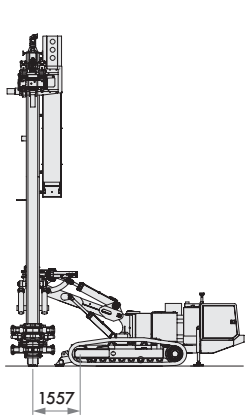
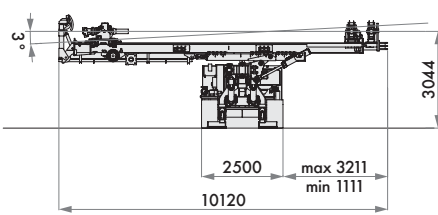
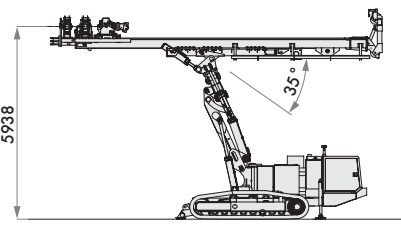
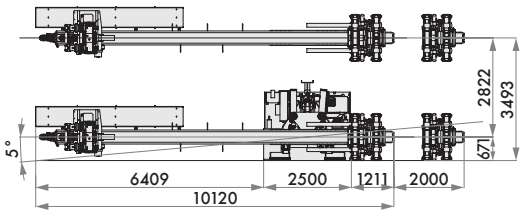
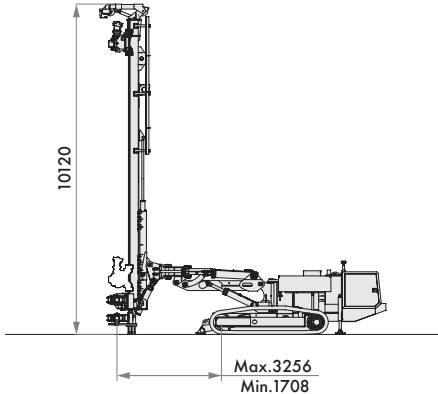
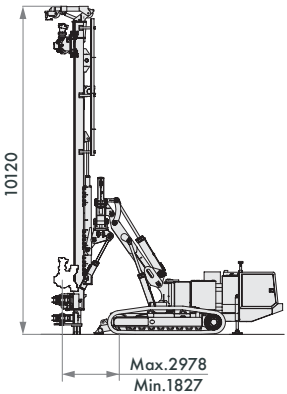

Morsa scorrevole
Casing extractor

C7 NG





OPTIONALS

Argano tipo A2 - tiro max. - 20 kN / Winch type A2 - max. line pull - 4,500 lbs

Martello esterno D21 / Hydraulic drifter type D21: 1800 blows/min

Caricatore a 2 aste fino a 9 metri / Rod carousel for 2 rods

Prolunga tralicciata / Lattice mast extension

Spostamento laterale testa / Lateral movement of rotary head

Falchetto idraulico / Hydraulically operated jib

Oliatore in linea / Oiler

Pompa acqua / Water pump

Pompa schiumogeni / Foam pump

Pompa lavaggio / High pressure cleaning pump