



**Hydraulic crawler drill**  
Perforatrice idraulica

**M6A-1**

## Dati tecnici

### Technical Specifications

# M6A-1



<b>Caratteristiche Carro</b>	<b>Undercarriage</b>		
Larghezza sottocarro	Overall width of undercarriage	7.6 ft	2310 mm
Larghezza pattini	Shoes width	15.7 in	400 mm
Lunghezza cingoli	Tracks length	9 ft	2783 mm
Velocità di traslazione	Travelling speed	0 ÷ 1.7 mph	0 ÷ 2,7 km/h
Pendenza max. superabile	Max. gradeability	37%	20°
Pressione al suolo	Ground pressure	106 PSI	7,5 N/cm <sup>2</sup>
Oscillazione cingoli	Oscillating tracks	+/- 15°	+/- 15°
<b>Motore</b>	<b>Engine</b>	<b>Deutz</b>	
Tipo	Type	<b>TCD 2013 L04 2V (EPA/COM III)</b>	
Potenza a 2300 rpm	Rated power at 2300 rpm	175 HP	129 kW
<b>Mast</b>	<b>Mast</b>		
Lunghezza mast	Mast length	17 ft	5200 mm
Corsa testa di rotazione	Stroke of rotary head	13 ft	4000 mm
Forza di estrazione	Extraction force	12,365 lbs	55 kN
Spinta sull'utensile	Crowd force	12,365 lbs	55 kN
<b>Morsa</b>	<b>Clamp</b>	<b>M2Z - M2SZ</b>	
Morsa di bloccaggio	Blocking clamp	Ø 1.6 ÷ 10 in	Ø 40 ÷ 254 mm
Forza di chiusura	Clamping force	32,600 lbs	145 kN
<b>Testa di rotazione</b>	<b>Rotary head</b>	<b>T1200 6V</b>	
Coppia max.	Max. torque	9,960 ft lb	13500 Nm
Giri max.	Max. speed	530 rpm	530 rpm
<b>Ingombri e pesi</b>	<b>Dimensions and weight</b>		
Lunghezza	Length	28.8 ft	8765 mm
Larghezza	Width	7.6 ft	2310 mm
Altezza	Height	9.6 ft	2924 mm
Peso attrezzatura	Weight of rig	26,455 lb	12000 kg



# M6A-1

## Dimensioni Dimensions

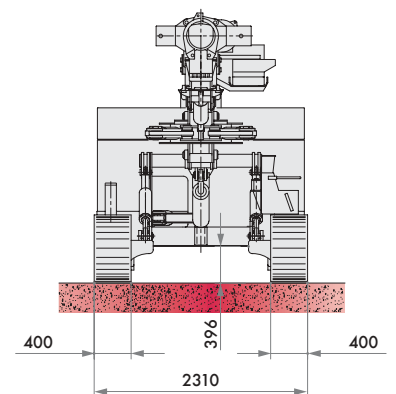
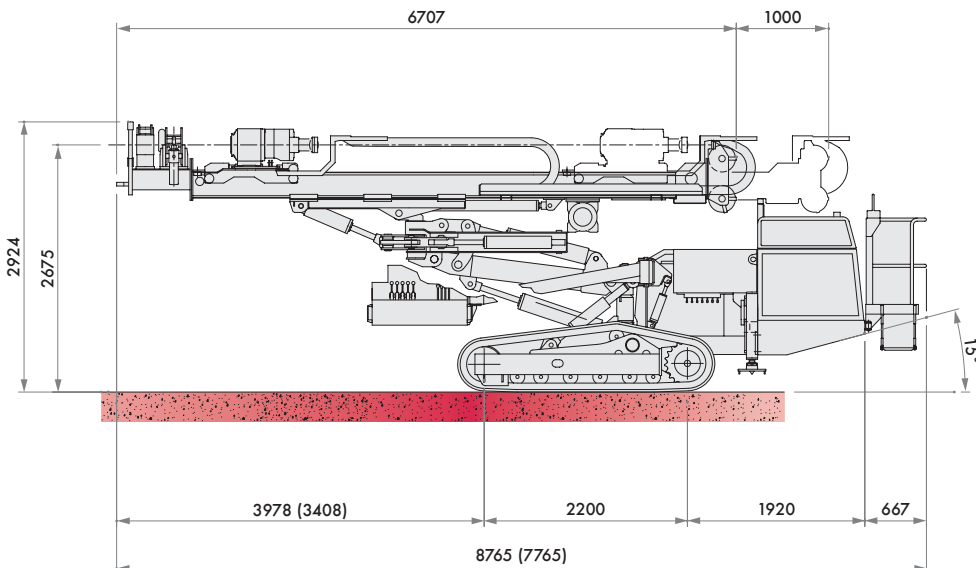
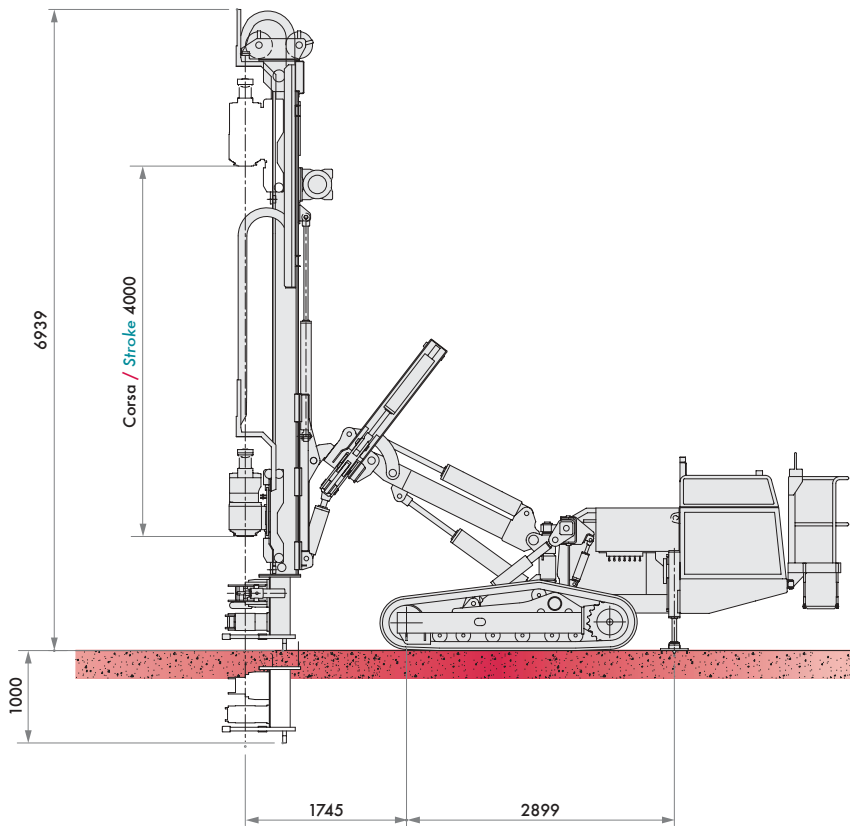



# M6A-1

## Movimentazioni mast Mast movements

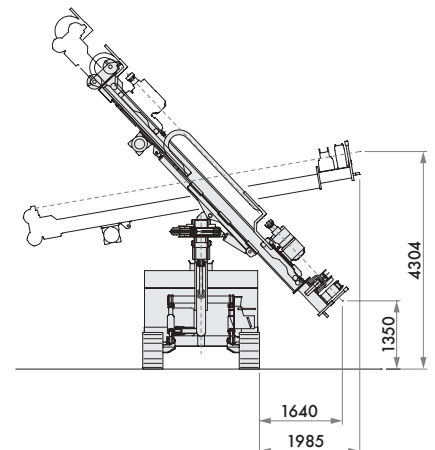
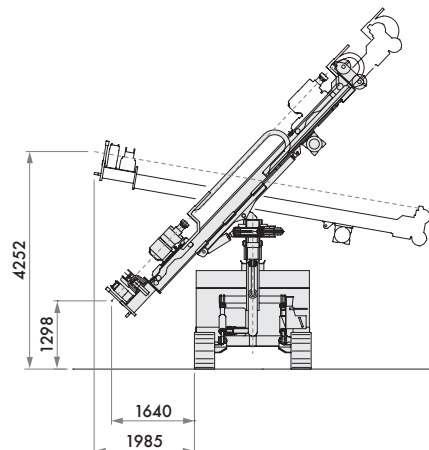
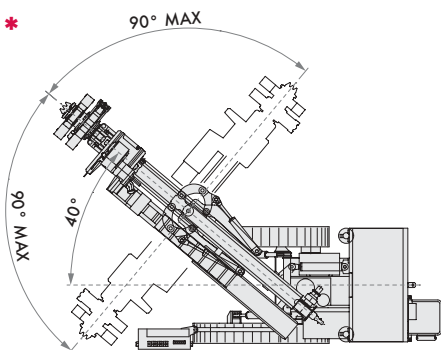
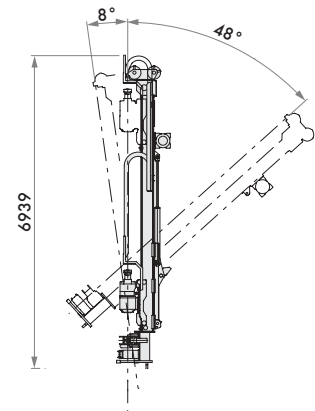
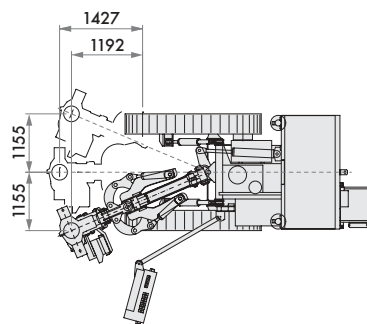
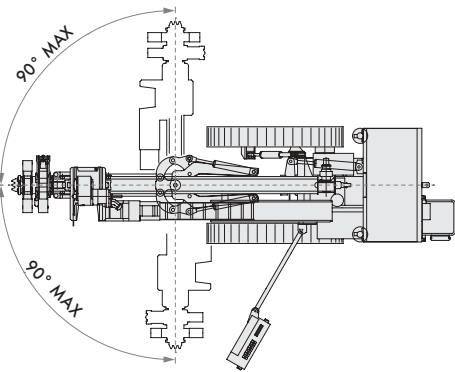
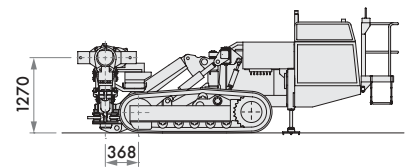
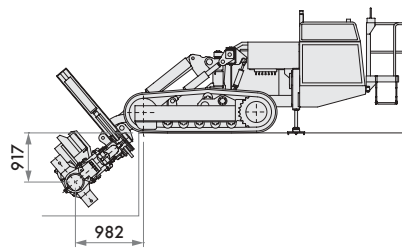
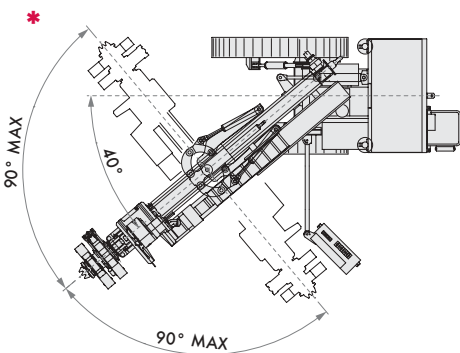
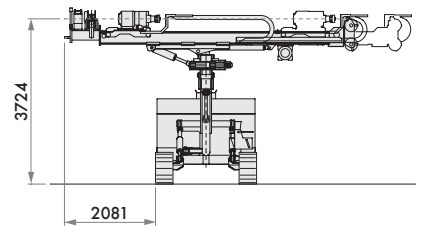
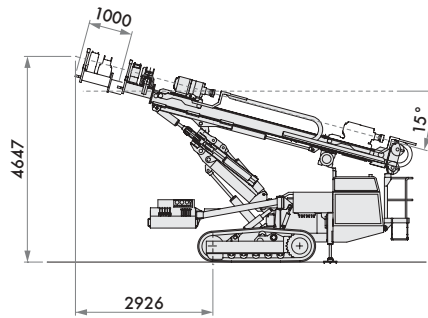
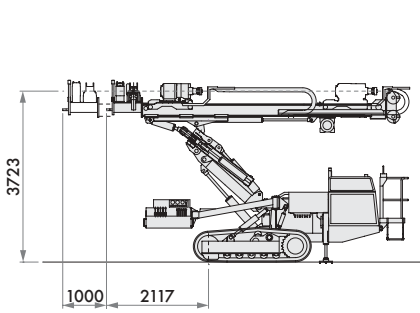

Movimentazioni ottenibili con testa singola - \*Posizione dipendente dalla configurazione macchina  
 Movements allowed with single rotary head - \*This position depending on configuration of machine

# M6A-1





## OPTIONALS

Morse M4 - M4S - Ø 60 ÷ 305 mm / Clamps M4 - M4S - Ø 2.4 ÷ 12  
 Argano tipo A2 - tiro max. - 20 kN / Winch type A2 - max. line pull - 4,496 lbs  
 Martello esterno D21 / External drifter type D21: 1800 blows/min  
 Spostamento laterale testa / Lateral movement of rotary head  
 Doppia testa / Twin rotary head: T1500 + T1200 6V  
 Caricatore a 2 aste - Ø max. 140 mm / Road carousel for 2 rods - Ø max. 5.5 in