



casagrande



Hydraulic crawler drill

Perforatrice idraulica

M9-1

Dati tecnici

Technical Specifications

M9-1





Caratteristiche Carro	Undercarriage			
Larghezza sottocarro	Overall width of undercarriage	8 ft	2450 mm	
Larghezza pattini	Track shoe width	19.7 in	500 mm	
Lunghezza cingoli	Overall track length	10.7 ft	3270 mm	
Velocità di traslazione	Travel speed	0 ÷ 1.23 mph	0 ÷ 1,98 km/h	
Pendenza max. superabile	Max. gradeability	37%	20°	
Pressione al suolo	Ground pressure	68 PSI	7,3 N/cm ²	
Oscillazione cingoli	Oscillating tracks	+16°/-14°	+16°/-14°	
Motore	Engine			Deutz
Tipo	Type	TCD 2012 L06 2V (EPA/COM III)		
Potenza a 2300 rpm	Rated power at 2300 rpm	200 HP	147 kW	
Mast	Mast	A	B	
Lunghezza mast	Mast length	20.7 ft / 6300 mm	27,6 ft / 8400 mm	
Corsa testa di rotazione	Stroke of rotary head	14.4 ft / 4400 mm	21.3 ft / 6500 mm	
Forza di estrazione	Extraction force	17,985 lbs / 80 kN	17,985 lbs / 80 kN	
Spinta sull'utensile	Crowd force	13,938 lbs / 62 kN	13,938 lbs / 62 kN	
Morse	Clamps	M2Z/M2SZ	M4/M4S	M5/M5S
Diametro	Diameter	40 ÷ 254 mm 1.6 ÷ 10 in	60 ÷ 305 mm 2.4 ÷ 12 in	90 ÷ 406 mm 3.5 ÷ 16 in
Forza di chiusura	Clamping force	145 kN 32,600 lbs	250 kN 56,200 lbs	250 kN 56,200 lbs
Testa di rotazione	Rotary head	T1200 6V		T2000
Coppia max.	Max. torque	13500 Nm 9,960 ft lb		17900 Nm 13,200 ft lb
Giri max.	Max. speed	530 rpm		223 rpm
Ingombri e pesi	Dimensions and weights			B
Lunghezza	Length	26.3 ft / 8010 mm		31 ft / 9657 mm
Larghezza	Width	8 ft / 2450 mm		8 ft / 2450 mm
Altezza	Height	10.2 ft / 3100 mm		10.2 ft / 3100 mm
Peso attrezzatura	Weight of rig	39,700 lb / 18500 kg		40,800 lb / 19000 kg

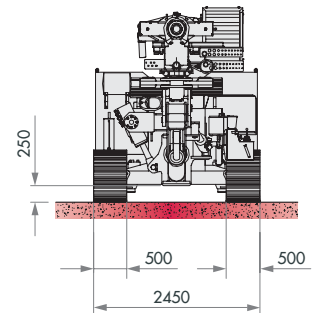
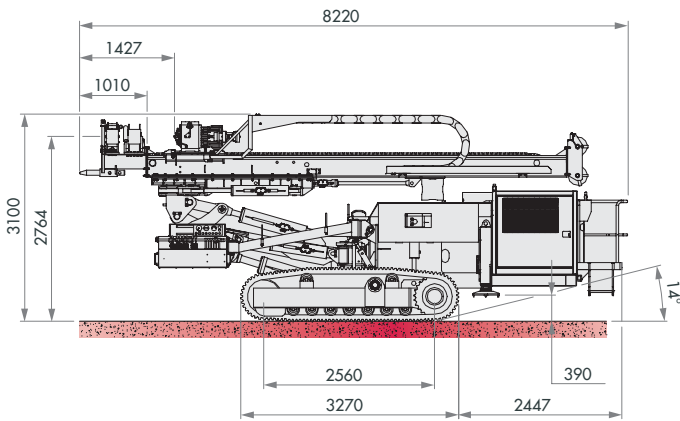
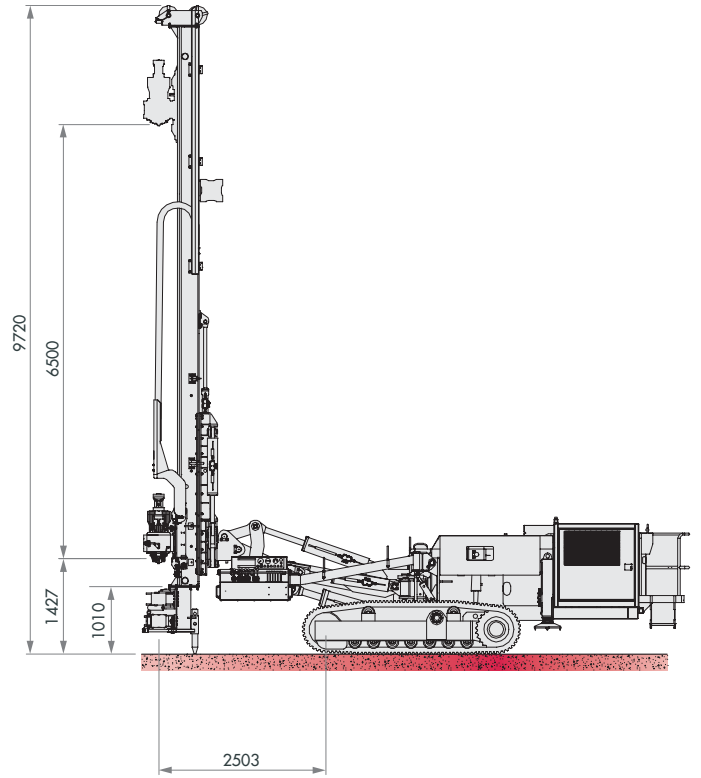
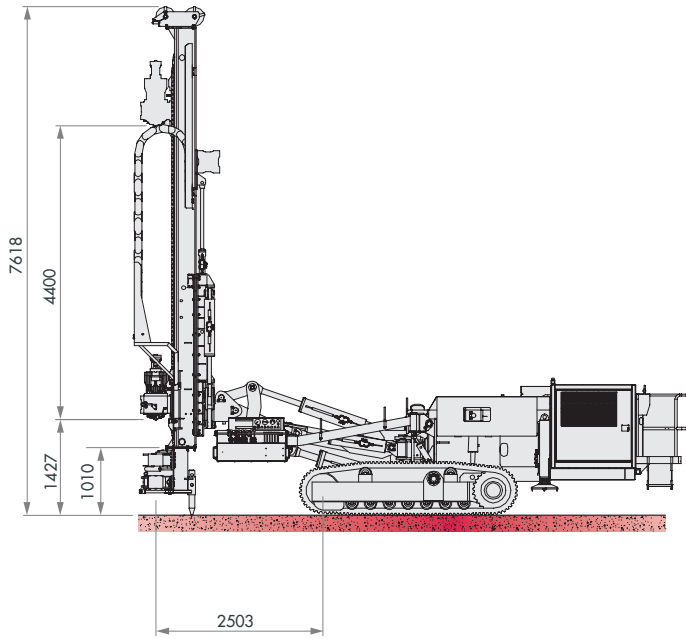

M9-1

Dimensioni Dimensions





M9-1

Movimentazioni mast Mast movements

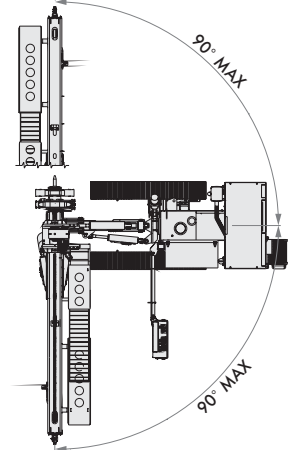
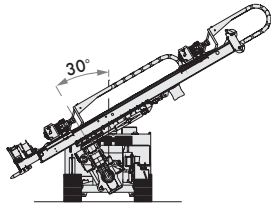
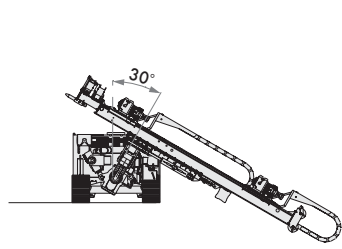
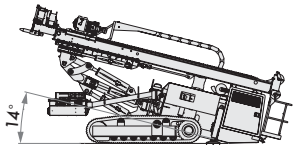
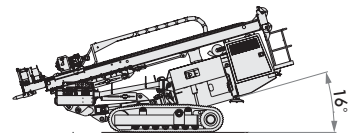
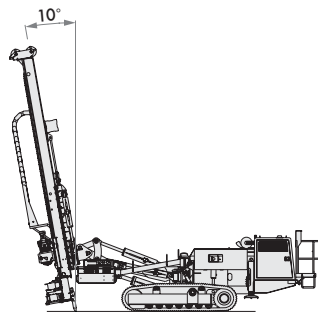
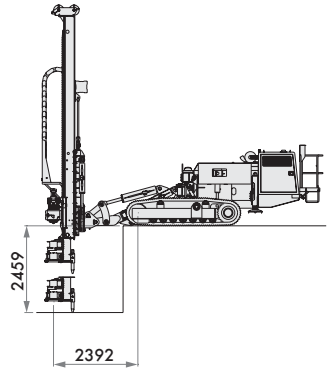
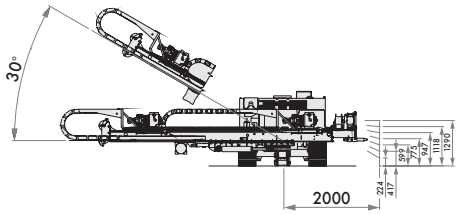
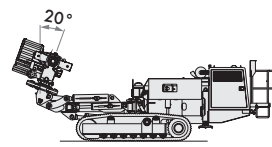
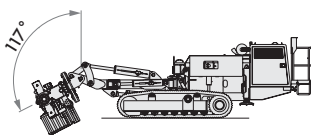
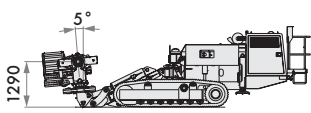
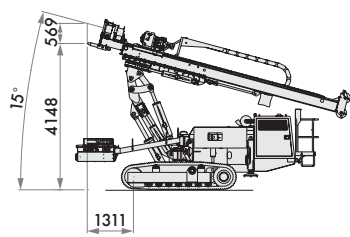
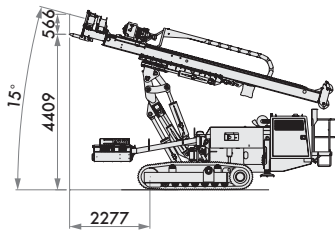
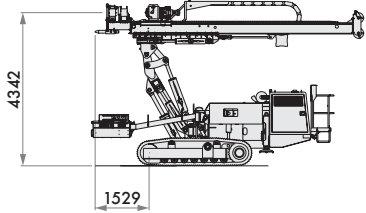

M9-1





OPTIONALS

Argano tipo A2 - tiro max. - 20 kN / Winch type A2 - max. line pull - 4,496 lbs
 Martello esterno D21 - 1800 blows/min / External drifter type D21 - 1800 blows/min
 Caricatore a 2 aste - Ø max. 140 mm / Rod loader for 2 rods - 5.5 in
 Caricatore a 7 aste - Ø max. 140 mm / Rod carousel for 7 rods - 5.5 in
 Prolunga tralicciata - 2 x 5000 mm / Lattice mast extension - 2 x 16.4 ft
 Gruetta idraulica / Hydraulic service hoist
 Spostamento laterale testa / Lateral movement of rotary head